

MHI
Copy 3

FM 4-25

WAR DEPARTMENT

**COAST ARTILLERY
FIELD MANUAL**



**SEACOAST ARTILLERY
SERVICE OF THE PIECE**

155-MM GUN

1940

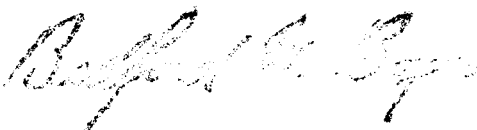

B. W. FOYES,
MAJOR, U. S. A.

B. W. Boyes,
Lt. Col., 250th. C.A.

FM 4-25

COAST ARTILLERY FIELD MANUAL



SEACOAST ARTILLERY SERVICE OF THE PIECE 155-MM GUN

Prepared under direction of the
Chief of Coast Artillery



**UNITED STATES
GOVERNMENT PRINTING OFFICE
WASHINGTON: 1940**

For sale by the Superintendent of Documents, Washington, D. C. - Price 15 cents

WAR DEPARTMENT,
WASHINGTON, *April 10, 1940.*

FM 4-25, Coast Artillery Field Manual, Seacoast Artillery,
Service of the Piece—155-mm Gun, is published for the
information and guidance of all concerned.

[A. G. 062.11 (2-26-40).]

BY ORDER OF THE SECRETARY OF WAR:

G. C. MARSHALL,
Chief of Staff.

OFFICIAL:

E. S. ADAMS,
Major General,
The Adjutant General.

TABLE OF CONTENTS

	Paragraph	Page
SECTION I. GENERAL.		
Scope -----	1	1
References -----	2	1
II. ORGANIZATION.		
Composition -----	3	1
Gun squad -----	4	2
Ammunition squad -----	5	2
Formation -----	6	3
III. DUTIES OF PERSONNEL.		
Battery executive -----	7	3
Assistant executives -----	8	4
Gun commander -----	9	4
Platoon chief of ammunition -----	10	8
Mechanic -----	11	8
Telephone operators -----	12	8
IV. NOTES ON THE SERVICE OF THE PIECE.		
General instructions -----	13	9
Operation of breech -----	14	9
Service of ammunition -----	15	9
Loading -----	16	10
Pointing and firing -----	17	11
Drill during simulated fire -----	18	12
V. SAFETY PRECAUTIONS.		
General -----	19	12
Misfires -----	20	13
VI. CARE AND ADJUSTMENT OF MATÉRIEL.		
Lubrication -----	21	16
Refilling recuperator -----	22	16
Refilling recoil cylinder -----	23	17
Firing mechanism -----	24	18
VII. EMBLACEMENT FOR FIRING.		
Definitions -----	25	18
Placing gun in firing position -----	26	19
Preparing spade holes -----	27	20
Attaching and anchoring spades -----	28	21
Preparing recoil pit -----	29	21
Ammunition squad -----	30	22
Caterpillar bands -----	31	22
Platforms -----	32	23
Permanent emplacements -----	33	25
VIII. WITHDRAWAL FROM POSITION AND PREPARATION FOR THE MARCH.		
General -----	34	25
March order -----	35	26
Ammunition squad -----	36	27
Inspection -----	37	27
IX. DRILL TABLE -----		28
APPENDIX. LIST OF REFERENCES -----		29

COAST ARTILLERY FIELD MANUAL

SEACOAST ARTILLERY

SERVICE OF THE PIECE

155-MM GUN

(The matter contained herein supersedes TR 435-184, June 26, 1936, including C 1, January 3, 1939.)

SECTION I

GENERAL

■ 1. SCOPE.—*a.* This manual prescribes the service of the piece for the 155-mm gun for use against naval targets. The duties of the members of the gun section in the service of the piece are shown in the drill table in section IX.

b. The preparation of the carriage for the march, maneuvering into position, and the service of the piece prescribed herein are intended as guides for the battery commander. Minor changes in the details of maneuvering and of the service of the piece may be made to meet local conditions.

■ 2. REFERENCES.—The references listed in the appendix should be consulted, especially those pertaining to ammunition and to the operation, care, and maintenance of matériel.

SECTION II

ORGANIZATION

■ 3. COMPOSITION.—*a.* Each gun emplacement is manned by a gun section consisting of a gun squad and an ammunition squad. The gun commander, a member of the gun squad, is chief of section. The peace strength of the gun section is 13 enlisted men; the war strength is 18 enlisted men (T/O 4-37).

b. In addition, one chief of ammunition, one artillery mechanic, and one telephone operator are authorized for each platoon (two gun sections).

■ 4. GUN SQUAD.—The gun squad (11 enlisted men) consists of the gun commander, gun pointer, elevation setter, and 8 cannoneers numbered from 1 to 8, inclusive. Men are assigned to permanent positions according to their aptitude, but will be interchanged frequently in drill positions to develop flexibility and facilitate replacement.

■ 5. AMMUNITION SQUAD.—At peace strength, the ammunition squad consists of 2 cannoneers numbered 9 and 10. These cannoneers are the tractor drivers of the gun section. At war strength, the ammunition squad consists of 5 cannoneers numbered from 9 to 13, inclusive. The tractor drivers have no duties in the service of the piece in a war strength organization.

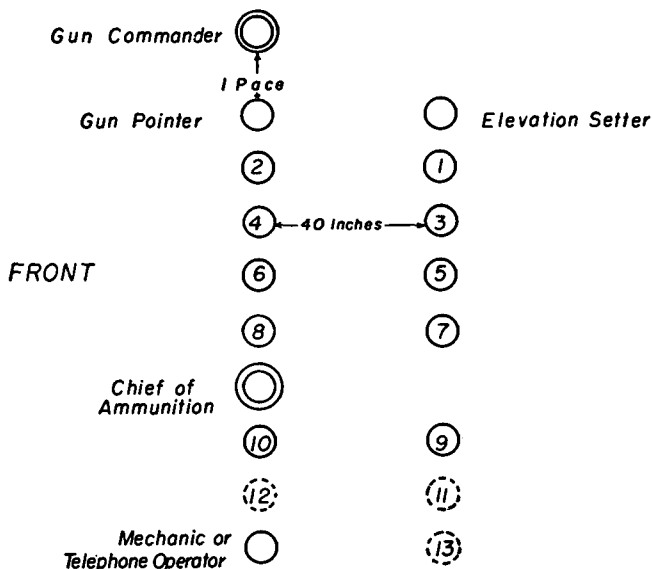

FIGURE 1.—Formation of gun section.

NOTE.—Nos. 11, 12, and 13 are for war strength organization only.

■ 6. **FORMATION.**—Each gun section assembles in two ranks with 4 inches between files and 40 inches between ranks (fig. 1). Unnumbered cannoneers form on the right of their squads in both front and rear ranks. Numbered cannoneers form in the order of their numbers from the right, even numbers in the front rank and odd numbers in the rear rank. Platoon chiefs of ammunition form with the first and third gun sections in the front rank on the right of the ammunition squad and are not covered off. Artillery mechanics and platoon telephone operators form on the left of the gun sections, mechanics with the first and third sections, and telephone operators with the second and fourth sections. After forming the section, the gun commander takes post in the front rank 1 pace to the right of the gun pointer.

SECTION III

DUTIES OF PERSONNEL

■ 7. **BATTERY EXECUTIVE.**—*a.* The battery executive commands the firing battery (two gun platoons and machine gun detail).

b. He supervises the emplacement and the preparation for firing of the guns of the battery.

c. He selects positions for, and supervises the emplacement of, the machine guns of the firing battery.

d. He is responsible to the battery commander for the technical handling of the guns, for the efficiency of the gun sections, for the condition of the matériel and ammunition under his charge, and for the observance of all safety precautions pertaining to the service of the piece.

e. He receives the reports of the assistant executives and reports to the battery commander, "Sir, firing battery in order," or reports defects which he is unable to remedy without delay.

f. At the conclusion of the drill or firing, the battery executive commands: **REPLACE EQUIPMENT**, inspects the gun positions, and reports to the battery commander. In case of withdrawal from position he gives the necessary commands and supervises the operation.

■ 8. ASSISTANT EXECUTIVES.—*a.* Each assistant battery executive commands a platoon (two guns) of the firing battery.

b. He supervises the emplacement and the preparation for firing of the guns of his platoon.

c. He is responsible to the battery executive for the technical handling of the guns, for the efficiency of the gun sections, for the condition of the matériel and ammunition under his charge, and for the observance of all safety precautions pertaining to service of the piece.

d. He inspects the matériel of his platoon and personally verifies the adjustment of all pointing devices as frequently as is necessary to insure accuracy. He tests all firing mechanisms before each drill or firing, paying special attention to the safety features. He verifies the filling of the recoil cylinders and recuperators and checks the operation of the breechblocks before firing.

e. He receives the reports of the chiefs of section and reports to the battery executive, "Sir, No. (Nos.) ----- in order," or reports defects which he is unable to remedy without delay.

f. He exercises general supervision over the loading and pointing. Should it become apparent that neither piece will be laid in time, he commands: **RE-LAY**, and reports his action to the battery executive. Should circumstances arise after an emplacement has been reported ready which in his opinion would make it unsafe to fire, he commands: **CEASE FIRING**, and reports his action to the battery executive who notifies the battery commander.

■ 9. GUN COMMANDER.—*a.* The gun commander (a noncommissioned officer) is in charge of the gun section and is also chief of the gun squad. He is responsible to the battery executive for—

- (1) Training and efficiency of personnel.
- (2) Condition of matériel.
- (3) Emplacement of the piece and its preparation for firing, including fortification and camouflage of emplacement, when necessary.
- (4) Firing the piece.
- (5) Observance of all safety precautions.
- (6) Police of emplacement.

b. At the command **PREPARE FOR ACTION**, given while the gun is on the road in march order, he directs the maneuver of the gun to the designated position and supervises the preparation of the emplacement. After the gun is emplaced ready for firing or the section arrives at the emplacement already occupied, he commands: 1. **DETAILS**, 2. **POSTS**, and supervises the procurement of equipment. After all details have reached their posts (fig. 2), he commands: **EXAMINE GUN**. He then personally makes an inspection of the trails and spades, wheels and wheel chocks, replenisher and recuperator gages, axle pivot pin, and recoil and counter-recoil piston nuts. He then commands: **REPORT**, receives the reports of the members of the gun squad as called for in the drill table (sec. IX), and reports to the assistant battery executive, "Sir, No. ----- in order," or reports any defects he is unable to remedy without delay.

c. When necessary to verify the section, he gives the command: **CALL OFF**. The cannoneers of the section call off their titles or numbers in succession, beginning with the unnumbered members of the section, followed by the numbered members in order.

d. He indicates to the ammunition detail the projectile, fuze, and powder charge to be used.

e. At the command **TARGET** he repeats the command and target designation. When the target is visible from the gun position, he assists the gun pointer in locating the target by sighting over the line of metal and directing the traversing of the piece. As soon as the gun pointer is on the target (or aiming point), the gun commander reports or signals to the assistant battery executive, "Sir, No. ----- on target."

f. At the command **COMMENCE FIRING**, the projectile, fuze, and powder charge having been designated, he gives the command: **LOAD**. He also commands: **LOAD** before each round of a series. He supervises the service of the piece. In case II firing, unless otherwise directed, the piece is fired at the command of the gun pointer. In case III firing and in case II firing, when so directed, the gun commander places himself in a position to be seen by No. 1. After receiving the reports "Set" and "Ready" from the elevation setter and gun pointer, respectively, he raises his hand indicating that the piece is

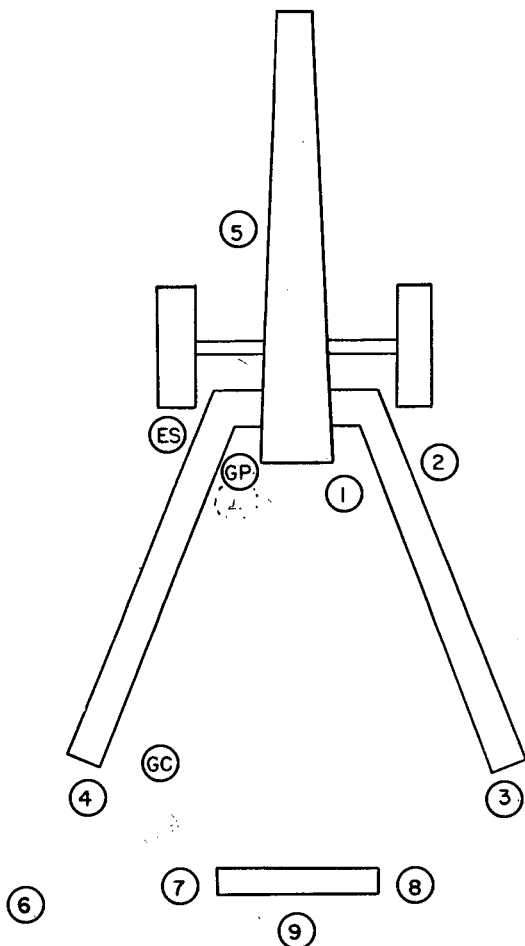

FIGURE 2.—Positions of cannoners at the command DETAILS, POSTS.

ready to fire. In case III firing, he commands: 1. NO. -----, 2. FIRE, and brings his hand to his side at the sounding of the proper time interval signal.

g. At the command CEASE FIRING, the gun commander repeats the command, or if the number of rounds has been specified the gun commander gives this command on the firing of the last round and reports to the executive, "Sir, No. ----- (so many) rounds fired." Should the gun be loaded at the command CEASE FIRING he causes the lanyard to be detached, the firing mechanism to be removed, and the hammer lock bolt locked, and then reports to the assistant executive, "Sir, No. ----- loaded." If directed to unload, he gives the command: UNLOAD, and supervises the unloading of the gun, exercising particular care in the unseating of the projectile. (See par. 19f.)

h. In case III firing, he commands: RE-LAY, in case his gun is not pointed in time to fire when the time interval signal sounds; he repeats this command when it is given by the assistant executive.

i. At the command STAND FAST, he causes the lanyard to be detached, the hammer lock bolt locked, and takes such other precautions as may be directed.

j. In case of a misfire, he reports to the assistant executive, "No. -----, misfire," and the cause of the misfire if known. He is responsible for the observance of the precautions to be taken in such a case. (See pars. 20 and 21.)

k. At the command SUSPEND FIRING, he repeats the command, and causes the lanyard to be detached, the firing mechanism removed, and the hammer lock bolt locked.

l. At the command REPLACE EQUIPMENT, the gun commander repeats the command and supervises the securing of the piece and the replacement of equipment. If the piece has been fired, he supervises the cleaning of the breechblock, and the proper and sufficient oiling of all bright parts and bearing surfaces. The piece being secured and equipment replaced, he forms his section.

m. He keeps a record of the number of rounds fired by his gun during a practice or action, showing the date and approximate time, and keeps the gun book posted accurately and up to date.

■ 10. PLATOON CHIEF OF AMMUNITION.—*a.* The platoon chief of ammunition is responsible to the assistant executive that the proper projectiles, fuzes, powder, and primers are served as required or ordered. Normally he has charge of the platoon ammunition pits or shelters serving two guns.

b. He is responsible to the assistant executive for the construction and camouflage of the ammunition pits or shelters pertaining to his platoon.

c. He keeps a record of all ammunition received and that used by each gun, exercising particular care that projectiles and fuzes are listed under proper name and type.

d. He sees that the projectiles are arranged by weight groups so that projectiles of one weight will be fired consecutively.

e. He keeps the assistant executive informed regarding ammunition on hand, reports defects found, and causes unused increments of powder charges to be disposed of as directed (normally by burning).

f. He keeps a thermometer in a selected powder container and reports the temperature of the powder when called for by the executive.

g. He is responsible for the protection of the ammunition against water, dampness, fire, and the direct rays of the sun.

■ 11. MECHANIC.—The platoon mechanic is the custodian of the supplies pertaining to the platoon to which assigned. He issues such equipment, tools, oil, paints, and cleaning materials to the members of the gun section as may be necessary for the service and care of the guns and accessories. He is responsible to the assistant executive for the condition of the supply trucks or storerooms pertaining to his platoon and the supplies contained therein. Assisted by other members of the platoon, he makes such minor repairs to the matériel as can be made with the means at hand.

■ 12. TELEPHONE OPERATORS.—Two platoon telephone operators are available to the firing battery. They should be used to operate the elevation and azimuth (deflection) display boards and as recorders. When the battery commander's station is too far from the firing battery for communication

by voice, an additional operator should be provided for the command line.

SECTION IV

NOTES ON THE SERVICE OF THE PIECE

■ 13. GENERAL INSTRUCTIONS.—The service of the piece should be conducted with dispatch and precision and with as few orders as possible. Except for the necessary orders, reports, and instructions, no talking should be permitted. Cannoneers change positions at a run. Loading with dummy ammunition and pointing the piece as for service firing is the normal practice at drill. Drill primers or fired service primers should be used at drill. Commands should be given in the prescribed form. Signals should be substituted for commands whenever practicable.

■ 14. OPERATION OF BREECH.—*a. To open.*—The firing mechanism having been removed, No. 1 presses down on operating lever handle to disengage operating lever latch and pulls backward and outward on operating lever until operating lever latch engages in catch on operating lever catch bracket, locking carrier in the open position.

b. To close.—No. 1 presses down on operating lever handle, disengaging operating lever latch, and pulls operating lever inward then forward until operating lever latch engages in catch on block carrier, locking lever in the closed position.

■ 15. SERVICE OF AMMUNITION.—*a.* When action or target practice is imminent, ammunition is stored near the guns in ammunition pits or shelters. Normally one projectile pit and one powder pit are provided for each platoon of two guns, primers and fuzes being stored in any convenient place away from the projectiles and powder charges, and protected from the weather.

b. For convenience in the service of projectiles, a rack or table (referred to in this manual as a projectile board) is usually provided for each emplacement to hold a limited number of projectiles which are about to be fired.

c. Powder charges are removed from their containers only as they are needed; for any given round, the powder charge

must not be brought near the breech until the preceding round has been fired, the chamber sponged, and the mushroom head wiped.

d. Projectiles are fuzed only as required and in the following manner. Unscrew adapter plug from fuze socket, then insert fuze, being careful to note that it is fitted with its felt or rubber washer, and screw it home by hand. Seat fuze with fuze wrench but without using any great force. If there is any difficulty in screwing the fuze home, it should be removed and another inserted. If the same trouble is experienced with the second fuze, the shell should be rejected. Fuzes must be handled with the greatest care. A long fuze must not be screwed into a projectile until the projectile is on the loading tray and about to be loaded.

e. Prior to firing, the primer pouch should be examined to make certain that it contains live primers only. Fired primers should be discarded as soon as they are removed from the firing mechanism.

f. All members of the gun section should be familiar with the appearance of a *service* powder charge, paying particular attention to the difference between the igniter end and the front end of the charge (both normal charge and supercharge). A misfire or hang fire will occur if the powder charge is loaded with the igniter against the projectile.

■ 16. LOADING.—*a.* At the command TARGET, No. 9 fuzes a projectile and places it in readiness on the projectile board. When the command COMMENCE FIRING is given, the gun commander commands: LOAD. No. 9 places fuzed projectile in loading tray and Nos. 7 and 8 bring up loading tray and insert it in breech recess. In inserting loading tray in breech, care must be taken not to burr or damage the threads in the breech or on the breechblock. The two lateral guides should be slid into the spaces cut in the breech sectors and the bronze stop on the bottom of the tray engaged in the socket in the breech ring.

b. No. 3 places head of rammer against base of projectile and pushes projectile clear of loading tray. Nos. 7 and 8 take their posts, No. 7 carrying loading tray. No. 4 takes his place on rammer, and No. 3 commands: HOME RAM. Nos. 3 and 4 ram projectile. No. 4 releases rammer and No. 3

withdraws it and returns it to rammer rest. No. 6 then places powder charge in powder chamber. When the powder charge is inserted, it should be pushed into the powder chamber to such a distance that the breechblock in closing will give the charge a final push into the chamber.

c. No. 1 closes breech and No. 2 hands him a primed firing mechanism which No. 1 inserts in breechblock. No. 1 attaches and grasps lanyard, unlocks percussion hammer lock bolt, steps to the rear and out of the line of recoil, calls "Lanyard," and stands facing the gun pointer (case II) or the gun commander (case III), awaiting the command or signal FIRE.

■ 17. POINTING AND FIRING.—*a.* For case II firing, the gun pointer sets on his sight the deflection received from the plotting room and traverses the piece until his line of sight is slightly ahead of the target. Concurrently, the elevation setter sets on the elevation drum the elevation received from the plotting room, elevates the piece until his level bubble is centered, calls "Set," and keeps the bubble centered as the piece is traversed. The gun pointer then centers the cross level bubble, traverses the piece until the vertical cross wire of his sight is on the target, and commands or signals: FIRE. If the piece is to be fired on the command of the gun commander (either at the command of the executive or on a firing signal), the gun pointer proceeds as before except that he calls "Ready" instead of commanding FIRE, and continues to track. He should remove his eye from contact with the sight just before the piece is fired.

b. For case III firing, the gun pointer sets on his sight the azimuth received from the plotting room and traverses the piece to put his line of sight on the aiming point. The elevation setter points the piece in elevation as described above, and as soon as his bubble is centered calls "Set." The gun pointer then centers the cross level bubble, traverses the piece until the vertical cross wire of his sight is accurately on the aiming point, and calls "Ready." The gun commander commands or signals: FIRE, at the sounding of the proper time interval signal.

c. At the command or signal FIRE, No. 1 pulls the lanyard. When the piece comes back into battery, he removes the firing mechanism, passes it to No. 2 for repriming, opens breech, and locks percussion hammer lock bolt. No. 4 sponges powder chamber. No. 1 sponges off the inner face of breechblock, and when necessary cleans breech recess, vent, and breechblock threads, No. 5 measures the position of replenisher piston and reports it to the gun commander. If necessary, No. 5, under the supervision of the gun commander, bleeds the recoil cylinder. All members of the gun section stand ready for the next round.

■ 18. DRILL DURING SIMULATED FIRE.—*a.* Before a drill in which the gun is not to be fired, No. 2 removes the firing pin housing and firing pin and screws a drill plug in their place. The drill plug has a projection to the rear to take the blow of the percussion hammer and a projection to the front to provide normal compression of the firing pin spring so that the primer will be held in the primer holder. The purpose of the drill plug is to receive the blow of the percussion hammer in order to prevent the battering of the firing mechanism and the breaking of the firing pin. Before a drill in which the gun is not to be fired, the gun commander assures himself that the drill plug is in place on the firing mechanism.

b. For simulated fire using dummy ammunition, the following procedure is recommended:

(1) For the first and succeeding odd-numbered rounds, the operations of loading, pointing, and firing are as given above for service ammunition.

(2) For the second and succeeding even-numbered rounds, the operations of sponging and loading are omitted, and the operation of unloading is substituted therefor. As soon as the projectile is removed, No. 1 closes the breech, and the operations of pointing and firing proceed as for service ammunition.

SECTION V

SAFETY PRECAUTIONS

■ 19. GENERAL.—The following safety precautions, applying specifically to the 155-mm gun, are prescribed for peacetime

conditions. They indicate, in general, the principles to be followed under war service conditions. They are included in the drill in this manual where they apply.

a. The firing mechanism will not be inserted until the breechblock is rotated and locked in the closed position.

b. The percussion hammer lock bolt will be locked immediately after the breech is opened, and this bolt will not be unlocked until after the breechblock has been fully rotated and locked in the closed position, the firing mechanism inserted, and the gun is ready to be fired.

c. When firing high explosive shell with fuzes which are not classified as boresafe, the safety lock bolt on the percussion hammer will not be released until all members of the gun section have taken cover. It will then be released by the gun commander, who, after having assured himself that all other members of the gun section have taken cover, will take cover himself before giving the command: 1. NO. -----, 2. FIRE. (The gun crew is not required to take cover when firing high explosive shell in time of war.)

d. At the command SUSPEND FIRING OR CEASE FIRING, lanyards will be detached, firing mechanisms removed, and the hammer lock bolt locked.

e. The fuze plug will be left in a projectile until the fuze is to be inserted. Projectiles will not be fuzed until immediately before they are to be fired. Hoods will not be removed from long fuzes until the fuze is screwed in the projectile and the projectile is about to be loaded.

f. When loaded with service ammunition, the piece will be unloaded only upon the specific orders of an officer. A shell fuzed with a long fuze will not be unloaded unless conditions prevent its being fired. If necessary to unload a shell fitted with this fuze, the special rammer head for handling such fuzes should be used. In any case, the force necessary to unseat the projectile and move it to the rear should be applied in the manner shown in figure 3. Duties of the cannoneers in unloading are as shown in the drill table in section IX.

■ 20. MISFIRES.—A misfire occurs if the piece fails to fire when desired. Failure of the piece to fire is due to one of two causes, failure of the primer to fire or failure of the propelling charge to ignite.

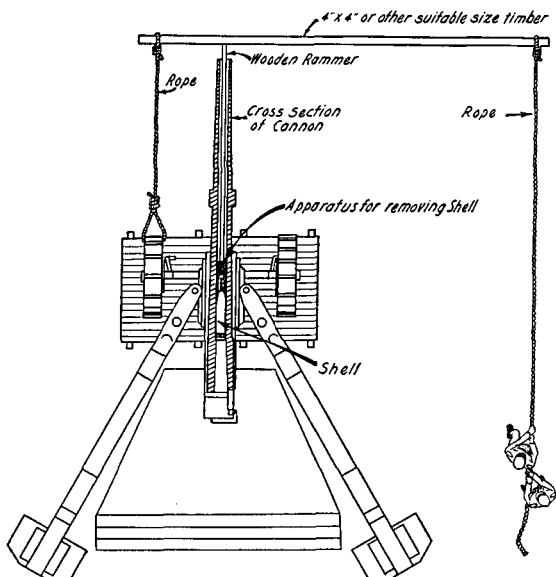

FIGURE 3.—Unloading projectile.

a. General precautions.—The following general precautions will be taken in all cases:

(1) The piece will be kept trained on the target or on a safe place in the field of fire.

(2) All persons will be kept clear of the part of recoil until after the breechblock is opened.

(3) When removing the firing mechanism, opening the breech, or reaming the vent, the operator will stand clear of the path of recoil and all other persons will be kept from in rear of the breech.

(4) In no case will the breechblock be opened before the primer is removed.

(5) Whenever a new primer is inserted and another attempt to fire results in failure, all precautions and procedure will be as prescribed for the first failure. The firing of more than two primers in an attempt to ignite the propelling charge usually is not justified.

b. Primer failures.—In case the discharge of the primer is not heard, the following procedure will be observed:

(1) At least three attempts will be made to fire the primer, the lanyard being pulled with considerable snap.

(2) If a special device (*d* below) is available which permits the lifting of the latch and the removal of the firing mechanism by a person entirely clear of the path of recoil, the primer may be removed after 2 minutes have elapsed since the last attempt to fire. If no special device is available proceed as in *c* below.

(3) When removing the firing mechanism, the operator will note whether or not the firing mechanism was fully screwed home. (The primer will not be hit properly unless the firing mechanism is screwed as far beyond the latch as it will go.)

(4) The primer, after removal, will be examined to determine whether or not it has fired.

(5) If the primer has fired, proceed as in *c* below.

(6) If the primer has not fired, the percussion head will be examined, and—

(a) If the head has been properly indented, the primer will be handled carefully and disposed of quickly due to the possibility of a primer hang fire. A new primer should then be inserted and an attempt made to fire.

(b) If the head has not been properly struck, and if the firing mechanism was found to have been properly seated (see (3) above), the firing mechanism should be inspected for the following faults:

1. Dirty or gummy parts.
2. Firing pin or firing pin spring broken.
3. Firing pin housing or primer holder loosened.

A new primer should then be inserted and an attempt made to fire.

c. Propelling charge failure.—In case the discharge of the primer is heard but the propelling charge has failed to explode, no attempt will be made to remove the primer or to open the breech until 10 minutes have elapsed after the firing of the primer. After 10 minutes the primer will be removed, a cleaning bit will be run through the vent, another primer will be inserted, and another attempt will be made

to fire. Failure of the propelling charge to ignite indicates an abnormal condition of the charge, such as missing igniter, igniter end of charge against the projectile, wet igniter, or igniter charge folded over and not accessible to the flash of the primer.

d. Special devices.—Special devices of various designs have been made which permit the lifting of the latch and the removal of the firing mechanism without exposing any part of the body to danger of injury by recoil. These devices are of local manufacture and are not articles of issue.

SECTION VI

CARE AND ADJUSTMENT OF MATÉRIEL

■ 21. LUBRICATION.—It is essential that all contact surfaces on the breech mechanism be kept well lubricated at all times. The cradle oil cups, the elevating and traversing mechanisms, the machined surfaces of the lower and upper carriages, and the trunnions must be oiled frequently. Complete instructions for oiling and greasing are contained in *TM 9-345. The various lubricants and cleaning and preserving materials issued by the Ordnance Department are described and their use prescribed in *TM 9-850.

■ 22. REFILLING RECUPERATOR.—The gun commander verifies the projection of the recuperator oil indicator. If the indicator projects 5 millimeters ($\frac{1}{5}$ inch), there is sufficient oil in the recuperator. If the indicator projects less than 5 millimeters, the recuperator should be drained and refilled. The procedure is as follows:

No. 5, who is in charge of the operation, removes filling and drain plug and allows recuperator to drain, the filling and drain valve release being used for this purpose. After the system is drained, the filling and drain valve release is removed and the drain plug replaced. No. 5, assisted by Nos. 6 and 7, brings up and primes the pump and connects copper tubing to recuperator filling hole. Nos. 6 and 7 operate pump handle, No. 5 counting the strokes. One hundred full strokes of the pump are applied. The copper tubing is then disconnected and the filling hole plug replaced. More complete

*See Appendix.

instructions for refilling the recuperator are contained in *TM 9-345.

■ 23. REFILLING RECOIL CYLINDER.—*a.* No. 5, under the supervision of the gun commander, measures the depth of the replenisher piston from the rear face of the replenisher. If the depth measures more than 200 millimeters, additional oil is necessary to fill the recoil cylinder to normal, this condition being indicated by a reading of 150 millimeters (5.9 inches). To fill recoil cylinder, Nos. 6 and 7 bring up pump, place it on left trail, and then prime it. No. 5 connects copper tubing to recoil cylinder filling hole after removing recoil cylinder filling hole plug. The pump is operated by Nos. 6 and 7 until replenisher piston rod is about 150 millimeters from rear face of replenisher. This reading should be not less than 100 millimeters nor more than 200 millimeters. No. 5 holds scale against replenisher piston. When recoil cylinder is filled, he disconnects copper tubing and replaces filling plug. Nos. 6 and 7 remove pump.

b. No. 5 must always be certain that no air is in recoil cylinder and that replenisher piston is not sticking. To insure the absence of air, unscrew filling and drain plug on left side of replenisher. Screw the union of filling pipe into filling hole loosely, then pump oil through filling pipe until all air is excluded. Set filling pipe union up tight. Remove filling and drain plug located at left front end of recoil cylinder. Screw in filling and drain valve release. Work the pump and force oil into recoil system until it flows from filling and drain valve release free of air bubbles; then remove filling and drain valve release. Continue to work the pump until rear end of replenisher piston is 150 millimeters (5.9 inches) from rear face of replenisher. Remove filling pipe union and replace filling and drain plugs.

c. Whenever end of piston in replenisher comes to a point 100 millimeters from rear face of replenisher, it is an indication that the amount of oil in recoil cylinder must be decreased. In an emergency when it is necessary to continue without an interruption, firing is permitted until the reading is down to 50 millimeters. To drain, screw filling and drain valve release into recoil cylinder drain hole and allow to drain.

*See Appendix.

During the draining, No. 5 holds millimeter scale against replenisher piston and calls off each 5 millimeter change as piston moves. When the distance has increased to the normal reading (150 mm), he removes filling and drain valve release and replaces plug.

d. When the matériel is to be subjected to rapid fire, replenisher should first be drained until replenisher piston is 200 millimeters (7.87 inches) from rear face of replenisher cylinder. (The normal rate of fire at naval targets requires this operation.)

■ 24. FIRING MECHANISM.—a. When the firing mechanism is correctly assembled and firing pin guide is pressed completely down, the end of firing pin should be flush with or below the front face of guide. With firing pin guide pressed completely down and firing pin pushed forward as far as possible, the front end of firing pin should protrude from 0.025 to 0.035 inch beyond the front face of guide.

b. Satisfactory service will not be obtained from firing mechanisms unless pertinent instructions in *TM 9-345 are carefully followed. Worn parts should be replaced rather than allowed to fail in service. Some of the common sources of trouble are dirty or gummy firing mechanisms, wrong grade of lubricant, the use of obsolete or defective parts, and improper assembly or adjustment.

SECTION VII

EMPLACEMENT FOR FIRING

■ 25. DEFINITIONS.—a. *Traveling position*.—The piece is said to be in traveling position when carriage is on its springs and is limbered, gun is retracted, and recoil lugs locked to traveling bar on trails.

b. *Firing position*.—The piece is said to be in firing position when gun is in battery and secured to recoil and counterrecoil piston rods, carriage is unlimbered, trails spread, trail pin nuts screwed down, spades attached, axle springs unshackled, and axle pivot pin inserted.

c. *Limbered*.—The gun carriage is said to be limbered when ends of trails rest on limber, draft rods are secured, and drawbar pins removed.

*See Appendix.

d. Unlimbered.—The gun carriage is said to be unlimbered when limber has been withdrawn and trails rest on blocks or on the ground.

e. Coupled.—The carriage is said to be coupled when limber drawbar is attached to pintle of tractor.

f. Uncoupled.—The carriage is said to be uncoupled when limber drawbar is not attached to pintle of tractor.

g. Front.—The front of a piece when limbered is the direction in which drawbar points; of a piece unlimbered, the direction in which muzzle points.

h. Right (left).—The direction right (left) is the right (left) of an observer facing the front.

■ 26. PLACING GUN IN FIRING POSITION.—*a.* Prior to the arrival of the piece at the position selected for its emplacement, the reconnaissance detail will have placed two stakes, one indicating the position of the pintle center of the gun, the other 50 yards or more to the front, indicating the direction of the center line of the field of fire. In maneuvering the piece into position, the gun commander is responsible that it is moved in over the line joining these two stakes, and that the piece is halted when its pintle center is over the proper stake.

b. At the command PREPARE FOR ACTION, given by the executive while the gun is on the road in march order, the gun commander directs the maneuver of the gun to the designated position and supervises the placing of the gun in the firing position and the preparation of the emplacement.

c. In placing the gun in the firing position, all odd-numbered cannoneers work on the right of the gun and all even-numbered cannoneers on the left.

d. The gun section having dismounted and the carriage having been brought over the desired position, the gun commander gives the command: UNCOUPLE. Nos. 7 and 8 jump to the drawbar. No. 7 unlatches pintle latch and assisted by No. 8 raises drawbar from pintle and signals the tractor driver to move on.

e. The gun commander then gives the command: IN FIRING POSITION. Nos. 1 and 2 line up chocks and check gun wheels. Nos. 3 to 8 remove spades and place them in rear of spade hole position, Nos. 1 and 2 remove gun trans-

lating rack covers and secure ratchet wrenches. No. 3 removes breech, muzzle, and piston rod covers and secures special recoil and recuperator wrench. Nos. 1 and 2 release traveling clips, attach ratchet wrenches, and working simultaneously under the direction of the gun pointer operate the wrenches to bring the gun into battery. No. 3 places himself between trails and screws on recoil and counterrecoil piston rod nuts, releases traveling bar, passing it to Nos. 1 and 2, and replaces special wrench in its chest.

f. At the command UNLIMBER, given by the gun commander, Nos. 4 to 8 bring up jack beam and place it in position, assisted by No. 3, who guides beam lug into eye of rear maneuvering lug and secures it with key. Nos. 4, 5, 6, and 7 bring up jacks and sufficient blocking. No. 8 inserts vertical drawbar pin. The tractor is backed up to drawbar held in position by Nos. 7 and 8, who lower it into tractor pintle. The limber may be handled by manpower if desirable. Nos. 5 and 6 disconnect brake cables. Nos. 1 and 2 unfasten and remove draft rods and seat assembly. Nos. 4, 5, 6, and 7 operate jacks simultaneously under direction of gun pointer until ends of trails clear limber. Nos. 1 and 2 place blocks or half blocks under trails to prevent them from falling should jacks slip. No. 8 inserts horizontal drawbar pin, and limber is moved straight to the rear on signal of the gun commander, either by the tractor or by all members of the section.

■ 27. PREPARING SPADE HOLES.—*a.* Nos. 1 and 2 remove blocking as trails are lowered; Nos. 4, 5, 6, and 7 operate jacks and lower trails until ends are about 1 foot above the ground. No. 11 removes trail coupling pin, and Nos. 1 and 2 place blocks so that they form an arc under trails over which trails are spread.

b. Nos. 5, 6, 7, and 8 open both trails simultaneously until stopped by trail locking bolts, and the gun commander marks on the ground the outline of spade holes, being guided by spade connecting plates.

c. The trails are partially closed by Nos. 5, 6, 7, and 8 so as to clear the positions for the spade holes. The entire gun section digs the spade holes in such manner as to leave un-

broken ground behind the spade faces to insure a minimum of back slips to the piece when fired.

■ 28. ATTACHING AND ANCHORING SPADES.—*a.* Nos. 1 to 8, inclusive, place handspikes through spade maneuvering rings, lower spades into spade holes, and open trails. When trails are fully opened, Nos. 1 and 2 screw down on trail locking bolts.

b. Nos. 1 and 2 unscrew spade locking bolts and swing them outward, Nos. 3 to 8, inclusive, lift spades into position under spade connecting plates, and Nos. 1 and 2 engage and screw up on spade locking bolts. When spade locking bolts are screwed up completely, Nos. 1 and 2 remove blocking from under trails, as Nos. 4, 5, 6, and 7 lower trails completely. Nos. 1, 2, 3, and 4 remove jacks and jack beam, and the other members of the gun section make spades secure.

c. Nos. 4, 5, 6, and 7 bring up jacks and sufficient blocking and adjust jacks under front maneuvering lugs. Under the supervision of the gun pointer, they operate jacks until spring is relieved of carriage weight. Nos. 1 and 2 remove spring shackle bolts, push shackles outward from ends of spring, and replace bolts in shackles. The gun pointer causes Nos. 4, 5, 6, and 7 to lower jacks until gun axle is in contact with the two axle centering pins. The gun commander inserts axle pivot pin and closes cover. If there is difficulty in inserting pin, he directs the maneuvering of jacks to bring pivot holes in line.

■ 29. PREPARING RECOIL PIT.—In order to provide sufficient space for the recoil of the gun when it is fired at the higher elevations, a recoil pit must be dug. This is done by the entire gun section under the direction of the gun commander. The outline, on the ground, of the recoil pit may be determined as follows: set the piece at a quadrant elevation of about 350 mils; place a straightedged board on top of the gun, one end bearing on the ground; traverse the gun through its arc, allowing the board to mark a line on the ground; elevate the piece to its maximum elevation, place the board under the recoil mechanism, traverse, and mark a second line on the ground. With these two lines as the forward and

rear limits, the pit is dug 32 inches deep, the floor approximately level, and the rear face stepped to facilitate the service of ammunition.

■ 30. **AMMUNITION SQUAD.**—The ammunition squad, under the supervision of the platoon chief of ammunition, constructs the ammunition pits or shelters and prepares ammunition for service. Under the supervision of the gun commander, members of the ammunition squad may be used to clear fields of fire and as relief for those members of the gun squad who are assigned the heavier duties in connection with the emplacement of the gun.

■ 31. **CATERPILLAR BANDS.**—*a. Attaching.*—The caterpillar bands, which consist of segments called wheel shoes, are always placed on the wheels before the gun leaves a hard road, and they must be attached to the carriage wheels before the gun is placed in the firing position. Three methods of attaching caterpillar bands are given below; the method to be used in any particular situation is left to the discretion of the battery executive.

(1) *First method.*—Place the caterpillar bands on the ground so that a band lies in front of each wheel in line with the direction the wheels will travel when the carriage is moved forward. As the space between the carriage and the limber wheels, and also between the limber wheels and tractor, is insufficient to permit the caterpillar bands to be laid at full length, they must be folded or buckled near the front in order to place them in the space available. The carriage, towed by the tractor, is moved forward so that the wheels will roll onto the shoes. Two men at the forward end of each band unfold and aline the shoes so that the ribs are centered between the tires of the wheel. When the wheels approach the forward end of the caterpillar bands, the carriage is stopped and the rear end of the band is lifted over the wheel. The two ends are connected by the connecting bolt held in place by a nut and cotter pin. By attaching a short rope to the rear shoe of each band and passing the rope over the wheel, the rear end of the band may be carried with, and over, the wheel by the forward motion of the latter, the

shoe being held to the wheel by a man holding the free end of the rope so that the bight rests on the wheel.

(2) *Second method.*—The caterpillar band is lifted and laid in position over the top of the wheel tires. The forward end of the band is placed on the ground directly in front of the wheel. The carriage is moved forward, towed by the tractor, until the wheel has rolled over the first two shoes. The ends of the sections are then connected as described above.

(3) *Third method.*—The wheel is raised off the ground by means of a jack, one end of the caterpillar band passed under the wheel, the other end lifted over the wheel, and the two ends connected as above. This method is rarely used.

b. Removing.—The caterpillar bands are not removed, unless the ground is very hard, until the carriage is on a hard road. A connecting bolt is removed near the ground in rear of each wheel. The carriage is then moved forward permitting the shoes to unwind from each wheel. When the carriage has cleared, the caterpillar bands are placed on the limbered trails as explained below.

c. Placing on carriage for transport.—A timber is placed along each trail in front of the traveling bar locks, extending beyond the front end of the trails, care being taken to prevent injury to the retracting rack and elevating wheel. Two small wooden blocks are placed under the timber to provide an even support. The wheel shoes, being coupled together in one caterpillar band for each wheel, are laid on the timbers on each side and securely lashed in place. When two caterpillar bands are placed on each trail, the first band is placed with the guide ribs up. A piece of wood of sufficient size and length is placed on each side of the rib as a spacer, then the second band is placed on top, guide ribs up, and lashed in place.

■ 32. PLATFORMS.—On firm ground, the wheel shoes will provide sufficient bearing surface for the wheels of the carriage. However, in soft, sandy, or muddy soil, platforms may become necessary. They are constructed as follows:

a. The six sill pieces are first placed in shallow trenches as indicated in figure 4, parallel to the direction of the center

line of field of fire, and upper surfaces flush with the surface of the ground. The platform timbers are placed on the sills at right angles to their longest dimension, and held in

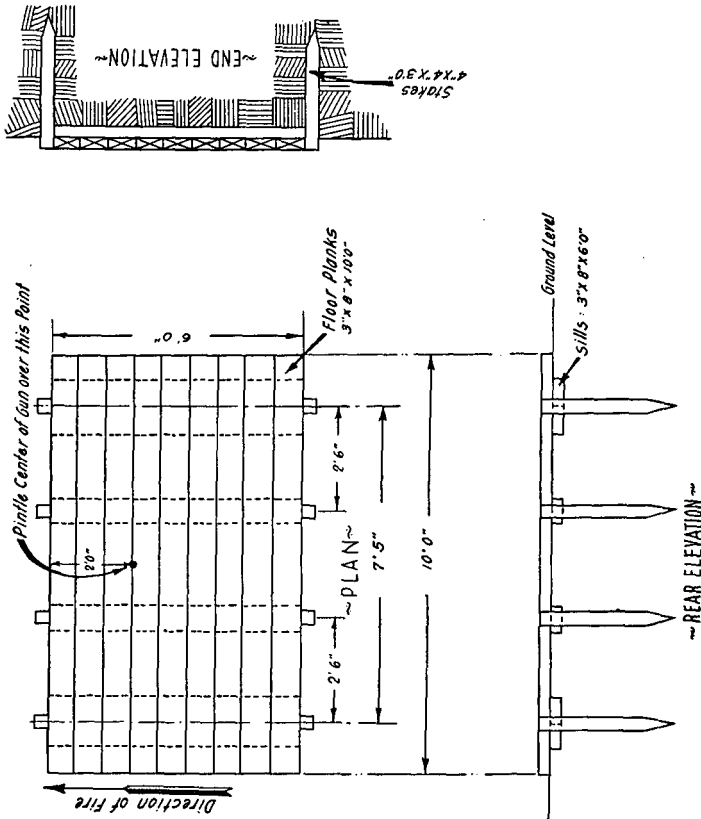

FIGURE 4.—Platform for 155-mm gun.

place by stakes driven vertically into the ground at the ends of the sill pieces as shown. The stakes are driven until flush with the top of the flooring. The platform is installed so as to place the stake marking the position for the pintle center of the gun at the point indicated in figure 4.

b. If only 2-inch planks are available, the platform is built of two layers of planks, the lower layer at right angles to the upper. No timber less than 3 inches thick is strong enough for the 155-mm gun.

■ 33. PERMANENT EMBLEMMENTS.—*a.* To overcome the limited traverse of the 155-mm gun carriage and provide for the wider field of fire required when the gun is used against fast-moving naval targets, reinforced concrete emplacements have been designed for construction in harbor defenses. These emplacements, constructed by the Corps of Engineers, are designed for 180° to 360° traverse. A 70-pound American Society of Civil Engineers rail, on which the spade seat plates slide during large changes in azimuth, is anchored and embedded in concrete, circumferentially about the center of rotation. The rail also takes the vertical and horizontal trail loads during firing. Concentric with the center of rotation is a raised concrete circle surrounded by a steel curb band; this curb fits inside the wheels of the carriage and prevents lateral displacement during firing.

b. In mounting a 155-mm gun on this emplacement, cribbing is first built to bridge the recoil pit. Wheel shoes are removed and the carriage is towed across the emplacement until the wheels are astride the raised concrete circle and the pintle center of the gun is over the center of the circle. The procedure outlined above, except with relation to the spades, is followed in placing the piece in firing position. The trail spades are not used. The original spade seat plates are removed and new plates of similar form substituted therefor. The new plates are grooved to enable them to slide on the rail as a shift of the trails becomes necessary. Shifting of the trails is accomplished manually.

SECTION VIII

WITHDRAWAL FROM POSITION AND PREPARATION FOR THE MARCH

■ 34. GENERAL.—It may be stated as a general rule that the same details handle the same elements of matériel in preparing the gun for the road (march order) as they handle

in preparing it for firing. Also, as is the case in preparing the piece for firing, all odd-numbered cannoneers work on the right of the gun and all even-numbered cannoneers on the left.

■ 35. MARCH ORDER.—*a. Preparation.*—At the command MARCH ORDER, the gun commander commands: LIMBER. The entire gun section under the supervision of the gun commander fills in the recoil pit. Nos. 5 and 6 release spade locking bolts, Nos. 1 and 2 procure blocking and place it near trails, Nos. 4 to 8 bring up and place jack beam in position, and No. 3 secures it by pin to maneuvering lug on rear of bottom carriage. Nos. 4, 5, 6, and 7 bring jacks to the front of carriage and place them under maneuvering lugs, and the gun commander removes pivot pin. Nos. 4, 5, 6, and 7, operating jacks under the direction of the gun pointer, raise carriage, and Nos. 1 and 2 engage shackles and shackle pins when spring is in position. The jacks are then lowered and removed. Nos. 4, 5, 6, and 7 bring up jacks and sufficient blocking, place jacks in position under ends of jack beam, and under the direction of the gun pointer raise trails until clear of spades. Nos. 1 and 2 release trail locking bolts.

b. Trails.—No. 4 directs closing of trails by Nos. 5 to 8, inclusive, and inserts coupling pin.

c. Limber.—Nos. 4, 5, 6, and 7 operate jacks under direction of gun pointer until trails are raised sufficiently to allow limber to be run under trail ends. Nos. 1 and 2 follow trails with blocking as they are raised. The entire gun section mans the limber under the direction of the gun commander and runs it into position under the ends of the trails; Nos. 4, 5, 6, and 7 reverse ratchet levers and lower trails onto limber under the direction of the gun pointer. Nos. 1 and 2 remove blocks in time to prevent trails from resting on blocks. No. 8 removes pin from drawbar seat and drawbar is lowered to the ground.

d. Spades and seat assembly.—The spades having been pulled from the ground by a tractor, Nos. 1 to 8, inclusive, under the direction of No. 1, place one of the spades on trails behind seat assembly position. Nos. 1 and 2 place seat assembly in position and engage and secure draft rods.

Nos. 1 to 8, inclusive, then place other spade in its position in front of seat assembly, and lash it in place with a rope. Nos. 7 and 8 connect brake-lever cable to brake-band cable.

e. Retracting gun.—Nos. 1 and 2 procure traveling bar and assist No. 3 in engaging center lug in groove on under side of breech ring. They then engage pinions in retracting racks. No. 3 sets screw securing traveling bar to breech ring. The elevation setter elevates, depresses, and traverses gun to facilitate operation. No. 3 unscrews counterrecoil and recoil piston rod nuts. Nos. 1 and 2, under the direction of the gun pointer, engage ratchet levers in position and work ratchet levers in unison during retraction. When traveling bar is seated in traveling bar lock, Nos. 1 and 2 engage and secure locking screws.

f. Coupling.—The tractor is coupled to drawbar by Nos. 7 and 8, and Nos. 1, 2, 3, and 4 remove chocks from under wheels. When necessary, caterpillar bands are placed on wheels by one of the methods described in paragraph 31*a*. If the platform has been used, the gun commander supervises its removal.

■ **36. AMMUNITION SQUAD.**—The ammunition squad, under the supervision of the platoon chief of ammunition, repacks unused ammunition and fills in the ammunition pits. Under the supervision of the gun commander, members of the ammunition squad may be used to assist those members of the gun squad who have the heavier duties to perform in connection with the withdrawal from position.

■ **37. INSPECTION.**—The gun commander inspects wheel hubs and steering gear for proper lubrication and tests the adjustment of brakes. The gun is then moved to its designated position on the road.

SECTION IX
DRILL TABLE
Service of the piece, 155-mm gun

Details	DETAILS, POSTS	(a) EXAMINE GUN (b) REPORT	TARGET	LOAD	CEASE FIRING
Gun pointer	Gets panoramic sight and telephone head set; removes sight bracket cover and places sight in bracket; connects head set to line; takes post on sighting platform facing front.	(a) Examines sight and traversing mechanism; tests telephone to plotting room. (b) Reports to gun commander, "Sight, traversing mechanism, and deflection telephone in order," or defects he is unable to remedy.	Sets deflection (azimuth) received from plotting room and traverses piece to put his line of sight on target (aiming point); when the vertical cross wire is on the target (aiming point), calls "On target"; continues to set data as received from plotting room and follow the target (point the piece in azimuth).	Repeats deflection (azimuth) received from plotting room and sets sight accordingly; keeps bubble in cross level centered; for case II firing, follows target with vertical cross wire of his sight by traversing piece, and, after hearing "Lanyard" from No. 1 and "Set" from the elevation setter, commands or signals: FIRE; for case III firing, completes the pointing in direction by traversing the piece; when his vertical cross wire is accurately on the aiming point (target) calls "Ready." (See par. 17.)	Continues receiving and setting data until command CEASE TRACKING is received.
Elevation setter <i>Addition of line</i>	Gets telephone head set, connects to line; takes post outside left trail, opposite quadrant sight, facing the sight.	(a) Examines sight micrometer and level, quadrant sight, and elevation mechanism; tests telephone to plotting room; verifies accuracy of quadrant sight. (b) Reports to gun commander, "Quadrant sight, elevating mechanism, and elevation telephone in order," or defects he is unable to remedy.	Sets elevation received from plotting room and centers longitudinal bubble by elevating or depressing piece; continues to set data as received from plotting room and keeps longitudinal bubble centered.	Repeats elevation received over telephone; sets elevation on quadrant sight; elevates or depresses piece until bubble is centered, completing the centering operation after breechblock is closed; calls "Set."	Continues receiving and setting data until command CEASE TRACKING is received.
No. 1 (breech detail)	Gets oilcan and waste; takes post 1 foot to right and 1 foot to rear of breech, facing to left.	(a) Assisted by No. 2, removes breech cover and places it in a convenient position outside trails or in rear of a gun position; opens breech; examines breechblock, vent, bore, and chamber; closes breech, inserts firing mechanism, attaches lanyard, and tests firing mechanism. (b) Reports to gun commander, "Breech and firing mechanism in order," or defects he is unable to remedy.	Removes firing mechanism and passes it to No. 2; opens breech; locks percussion hammer lock bolt; wipes off mushroom head and breech threads.	When piece is loaded, closes breech (if breech does not properly close reports, "Breech out of order"). After breech is fully rotated and locked in the closed position, receives loaded firing mechanism from No. 2 and inserts it in breechblock; attaches lanyard; unlocks percussion hammer lock bolt; calls "Lanyard"; fires piece at command FIRE of gun pointer (case II) or of gun commander (case III). <i>and moves to left of breech</i>	Detaches lanyard, removes firing mechanism and passes it to No. 2; opens breech; cleans breechblock, obturator, gas check seat, and vent. (If the piece is loaded with service ammunition the breech will not be opened unless the command UNLOAD is given.) <i>to right of breech</i>
No. 2 (breech detail)	Gets pouch containing reamer, vent cleaner, extra firing mechanism, lanyard, and primers; takes post outside right trail, on line with breech facing to left.	(a) Assists No. 1 in removing breech cover; examines firing mechanism; when breech is closed, passes firing mechanism and lanyard to No. 1. (b) No duties.	Receives firing mechanism from No. 1	Inserts primer in firing mechanism; passes loaded firing mechanism to No. 1; inserts primer in extra firing mechanism for next round. <i>falls breech</i>	Receives firing mechanism from No. 1; removes primer from firing mechanism; cleans and oils mechanism.
No. 3 (rammer detail) <i>No. 5 (u u)</i>	Assists No. 4 in bringing up sponging solution; brings up rammer and places it on rest near right trail, staff to rear; takes post in rear of right trail facing to front.	(a) Removes muzzle cover and puts it at the designated place. (b) No duties.	No duties	Places rammer against base of projectile and pushes projectile clear of loading tray; when loading tray has been removed, commands: HOME RAM, and assisted by No. 4 rams projectile; withdraws rammer and falls back to right trail.	If piece is to be unloaded, assisted by No. 4, extracts projectile.
No. 4 (sponge detail)	Assisted by No. 3, brings up sponge tub of sponging fluid; places it inside and near end of left trail; brings up chamber sponge and places it in tub; takes post in rear of left trail, facing to front.	(a) Sees that fluid is deep enough to cover head of sponge, and that the sponge fits properly in powder chamber of gun. (b) No duties.	No duties	While loading tray is being removed, grasps rammer stave in front of loading detail; assists in ramming projectile; returns to post at sponge tub, and sponges full length of powder chamber immediately after each round is fired.	If piece is to be unloaded, assists No. 3 in extracting projectile.
No. 5 (replenisher detail)	Gets millimeter scale for measuring position of replenisher piston, oil drain tube, and wrenches for drain plug and drain tube; takes post opposite and facing replenisher.	(a) Measures distance of replenisher piston from rear face of replenisher; when recoil or recuperator cylinders require draining or filling, duties as shown in paragraphs 22 and 23. (b) Reports to gun commander, in millimeters, the distance of replenisher piston from rear face of replenisher.	No duties	Measures and reports position of replenisher piston to gun commander after each round.	If piece is to be unloaded, assists in unseating projectile on call from No. 3.
No. 6 (powder serving detail)	Takes post at powder pit	(a) Assists ammunition detail in preparing powder charges. When necessary, brings up pump, assisted by No. 7, and assists No. 5 in refilling recoil or recuperator cylinders. (b) No duties.	No duties	Receives powder charge from No. 10, and moving at a run carries it to breech; as soon as projectile is rammed and breech clear, inserts powder charge.	If piece is to be unloaded, withdraws powder charge and carries it to No. 10.
No. 7 (loading detail)	Gets loading tray and places it on loading tray stand; takes post on left of projectile board, facing piece.	(a) When necessary, assists No. 6 in bringing up pump, and assists No. 5 in refilling recoil or recuperator cylinders. (b) No duties.	Nos. 7 and 8 carry loading tray to projectile board ready to receive fuzed projectile from No. 9.	Nos. 7 and 8 lift loading tray with projectile thereon, placing it in breech; No. 7 removes loading tray after projectile has been pushed clear of tray and before it is rammed home.	If piece is to be unloaded, Nos. 7 and 8 insert loading tray in breech and receive projectile, No. 7 steadying the backward movement of the projectile with an extra rammer or pick handle. They return tray and projectile to loading tray stand.
No. 8 (loading detail)	Gets loading tray stand and places it in rear of and in line with gun, between trails; takes post on right of projectile board, facing piece.	(a) No duties. (b) No duties.	Duties under No. 7 above	Duties under No. 7 above	Duties under No. 7 above.
No. 9 (ammunition detail)	Gets fuze wrench; takes post in rear of projectile board, facing piece.	(a) Inspects projectiles on projectile board, cleaning them if necessary. (b) No duties.	Repeats name or type of fuze called by gun commander; fuzes projectile for first round.	Places fuzed projectile in loading tray; fuzes another projectile for succeeding round.	Removes fuze from projectile and returns it to No. 11; removes projectile from loading tray, placing it on projectile board, and removes fuze.
No. 10 (ammunition detail)	Takes post at ammunition pit	(a) Opens powder cases and arranges powder containers in convenient order. (b) Reports "Ammunition in order."	Repeats projectile designation	Withdraws powder charge from container, removes increment charge if normal charge is ordered, and hands charge to No. 6.	Receives from No. 6 the withdrawn charge and replaces it in container.
No. 11 (ammunition detail) (war strength only)	Takes post at ammunition pit	(a) Opens box containing fuzes to be used (b) No duties.	No duties	Assists No. 9 in fuzing projectiles	Receives from No. 9 the fuzes removed from projectiles and disposes of them as directed.
No. 12 (ammunition detail) (war strength only)	Takes post at ammunition pit	(a) Assists other members of the ammunition squad as required. (b) No duties.	No duties	Places projectiles on projectile board as needed	No duties.
No. 13 (ammunition detail) (war strength only)	Takes post at ammunition pit	(a) Assists other members of the ammunition squad as required. (b) No duties.	No duties	Places projectiles on projectile board as needed	No duties.

NOTES

- At peace strength, Nos. 9 and 10 perform the duties assigned to Nos. 11, 12, and 13.
- At peace strength, projectiles and fuzes, in numbers based on expected needs, must be placed in the vicinity of the projectile board prior to contemplated action and during lulls in action.

APPENDIX

LIST OF REFERENCES

- Ammunition for 155-mm gun, M1918MI.....TM 9-1925 (now published as TR 1355-155B).
- Ammunition, general.....TM 9-905. (now published as TR 1370-A).
- Camouflage, cover, protection against air and chemical attacks, local security, machine gun defense.....FM 4-5.
- Care and maintenance of matériel.....TM 9-850 (now published as TR 1395-A); FM 4-20.
- Commands.....FM 4-5.
- Drill ammunition.....TM 9-905 (now published as TR 1370-D).
- Examination for gunners.....FM 4-150.
- Fire control and position finding.....FM 4-15.
- Firing tables.....155-B-4.
- Gunnery.....FM 4-10.
- Organization of the gun battery.....FM 4-5; T/O 4-37.
- Reconnaissance, selection, and occupation of positions.....FM 4-5.
- Safety precautions in firing.....AR 750-10; FM 4-20.
- Service at the emplacement.....FM 4-20.
- 155-mm gun matériel, M1918.....TM 9-345 (now published as TR 1305-155C).

